

# Globe

ENG Sectional and up-and-over doors operator



Advanced entrance technology

Rugged motor for total reliability  
Technological heart for operative safety  
Attractive and elegant design to complement the environment

### Versatile

Globe pull unit, installed on the ceiling and completed by DITEC original control and safety accessories perfectly automates any type of garage sectional and up-and-over doors.

### Functional

Thanks to the radio remote control you will be able to open it and have your garage lighted at the same time for better visibility and security at dark and in the event of bad weather conditions.

### Safe - with encoder

The advanced encoder system managing the stroke, the speed and the slow-down effects of the sectional door, detects obstacle presence on opening and closing and offers great operative safety.

### Dimensions

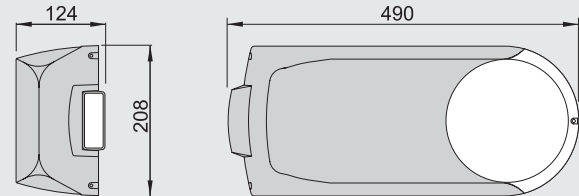

### Weight of the unit:

Globe 7: 9.4 kg - Globe 10: 11.1 kg



### Examples of installation

Sectional door

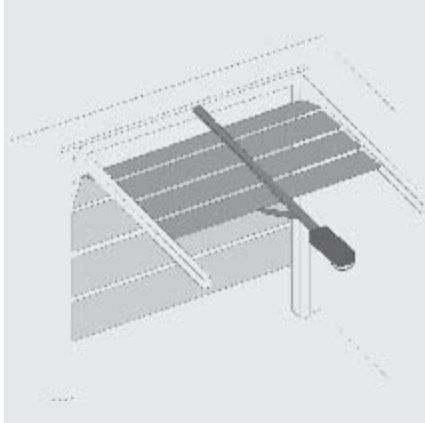

Spring up-and-over door

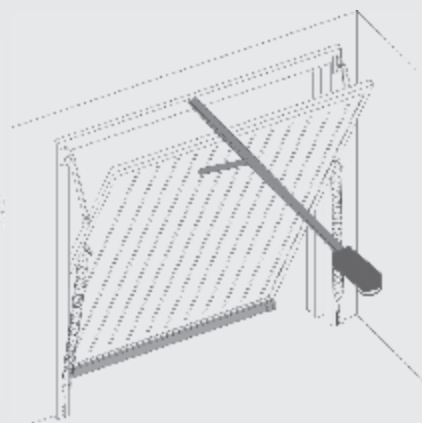

Counterweight up-and-over door

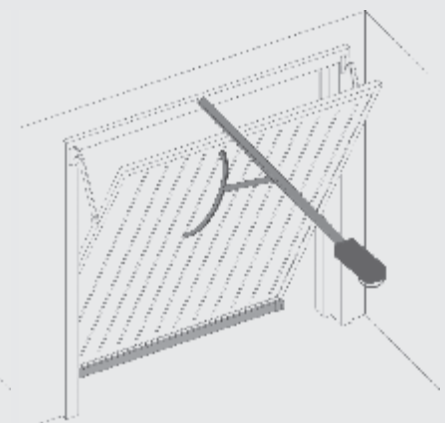

## Distinctive features and main functions

- Control panel complete with built-in radio receiver and courtesy light with fade effect
- 24 V DC motor to guarantee high safety standard
- Lock release system, internal by knob and remote by cord (optional)
- Stroke management by encoder
- Chain or, for more silent operation, toothed-belt transmission systems inserted into steel
- Full range of fitting accessories
- Easy mounting, building works not required



### Specific accessories



**Globe L**  
Chain extension set L = 1120 mm,  
for Globe 10L

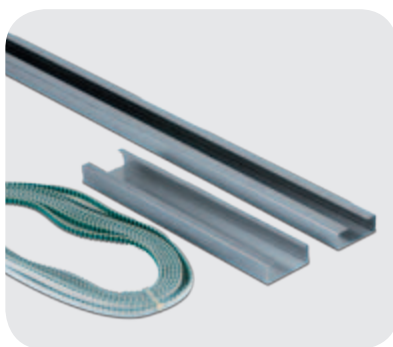

**Globe LV**  
Belt extension set L = 1120 mm,  
for Globe 7V and 10V



**ASB1**  
Kit for external cord-operated release system  
with lock, L = 900 mm



**BAT K1**  
Battery kit for power supply in case of power  
failure





**Globe C**  
Adapter for counterweight up-and-over door





**ASB2**  
Cord-operated release system L = 2000 mm

## Distinctive features

Description	GLOBE 7	GLOBE 10
Electromechanical actuator	for overhead and up-and-over doors with springs	for overhead and up-and-over doors with springs
Travel control system	encoder	encoder
Maximum capacity	7 m <sup>2</sup>	10 m <sup>2</sup>
Duty class	3 - medium	3 - medium
Intermittent operation	S2 = 30 min / S3 = 50%	S2 = 30 min / S3 = 50%
Power supply	 230 V~ / 50-60 Hz	 230 V~ / 50-60 Hz
Insulation class	class 1	class 1
Power input	0.7 A	1.2 A
Torque/Thrust	500 N	900 N
Opening speed	0.18 m/s (belt)	0.15 m/s (chain) - 0.18 m/s (belt)
Closing speed	0.12 m/s (belt)	0.10 m/s (chain) - 0.12 m/s (belt)
Release system for manual opening	by cable	by cable
Operating temperature	-20°C / +55°C	-20°C / +55°C
Protection rating	IP10	IP10
Product dimensions (mm)	490x208x124	490x208x124
Control panel	70R (built-in)	71R (built-in)



## System functions

	GLOBE 7	GLOBE 10
<b>Control panel</b>	<b>70R</b>	<b>71R</b>
Description	for 1 24 V= motor with incorporated radio	for 1 24 V= motor with incorporated radio
Mains power supply	 230 V~ / 50-60 Hz	 230 V~ / 50-60 Hz
Batteries ensure gate operation in the event of power cuts	■ (optional)	■ (optional)
Energy saving 	energy saving when in use	energy saving when in use
Number of motors	1	1
Motor power supply	24 V= / 8 A	24 V= / 12 A
Accessories power supply	24 V= / 0.3 A	24 V= / 0.3 A
Electrically operated lock		24 V= / 1.2 A
Flashing light - gives 3 seconds warning before automatically closing the gate	24 V=	24 V=
Gate open warning light		analogue
Courtesy light	■	■
Encoder to control speed and deceleration	■	■
ODS - Obstruction detection system causes the gate to stop or reverses operation when an obstruction is detected	■	■
Braking/slowing down - ensures best approach	■	■
Open control	■ (with dip-switch)	■ (with dip-switch)
Partly open control	■ (with radio only)	■ (with radio only)
Automatic timed close control	■	■
Inching control	■	■
Emergency stop	■	■
Emergency reverse	■	■
Soft Start	■	■



## Accessories

The wide range of DITEC accessories offers access system fitted with several types of control and monitoring devices.



### GOL 4 transmitters

Featuring four channels and fixed code and cloning option, or rolling code. Certified and compliant with current standards. Transmitter mountings: smartly designed, they can be fitted on any type of surface: from the car dashboard to a wall in the garage or in the house. The remote control can be stored in its practical housing and is always ready for use.



### Xel 2 and Lab 3 infrared sensors

These sensors allow the automation to be operated with the highest levels of safety. Can be mounted directly on a wall or on its own mounting. Modulated infrared beam. The sensors are also suitable for applications where space is at a premium.



### Xel 5 key operated selector switch

Fitted with a tamper proof or vandal resistant device. Can be mounted directly on a wall or on its own mounting.



### Sof safety edges

These are fitted to all entrance control systems to ensure maximum safety during opening and closing operations.



### Lan 4 digital combination systems

With digital vandal resistant combination keyboard. Up to 8 digit PIN number.

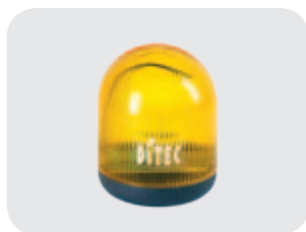

### Lamp H

24 V flashing light with flashing operation controlled from the control panel.



### GOL 4M keyboard operated transmitters, with digital combination

Coded four-channel control. Allows radio controlled motorised gates to be opened by entering a code. Wall mounted.



### Lan 7 control system with proximity control

Remotely operated identification system featuring TRANSPONDER technology. Allows identification without the need for a touch-controlled device.

When building the system, only use DITEC accessories and safety devices.

DITEC automations all feature CE marking and are designed and built in compliance with the safety requirements of the Machinery Directive (2006/42/EC), of the Electromagnetic Compatibility Directive (2004/108/EC) and of the Low Voltage Directive (2006/95/EC) and of other Directives, laws, specific standards for special products and situations.

DITEC S.p.A. reserves the right to make changes which may improve the products. DITEC S.p.A. always strives to improve its products. For this reason, the technical details featured in this catalogue are not binding.

The pictures shown in this leaflet were taken with the consent of those concerned or in public locations.

Further information can be found in the Technical Manuals available at the website: [www.ditec.it](http://www.ditec.it)



**DITEC S.p.A.** Via Mons. Banfi, 3 21042 Caronno P.la (VA) Italy Tel. +39 02 963911 Fax +39 02 9650314  
www.ditec.it ditec@ditecva.com

**DITEC BELGIUM** LOKEREN Tel. +32 9 3560051 Fax +32 9 3560052 www.ditecbelgium.be **DITEC DEUTSCHLAND** OBERURSEL  
Tel. +49 6171 914150 Fax +49 6171 9141555 www.ditec-germany.de **DITEC ESPAÑA S.L.U.** ARENYS DE MAR Tel. +34 937958399  
Fax +34 937959026 www.ditecespana.com **DITEC FRANCE** MASSY Tel. +33 1 64532860 Fax +33 1 64532861 www.ditecfrance.com  
**DITEC GOLD PORTA** ERMESINDE-PORTUGAL Tel. +351 22 9773520 Fax +351 22 9773528/38 www.goldporta.com **DITEC SWITZERLAND**  
BALERNA Tel. +41 848 558855 Fax +41 91 6466127 www.ditecswiss.ch **DITEC ENTRE/MATIC NORDIC** LANDSKRONA - SWEDEN  
Tel. +46 418 514 00 Fax +46 418 513 55 www.ditecentrematicnordic.com **DITEC TURCHIA** ISTANBUL Tel. +90 21 28757850  
Fax +90 21 28757798 www.ditec.com.tr **DITEC AMERICA** ORLANDO-FLORIDA-USA Tel. +1 407 8880699 Fax +1 407 8882237  
www.ditecamerica.com **DITEC CHINA** SHANGHAI Tel. +86 21 62363861/2 Fax +86 21 62363863 www.ditec.cn