

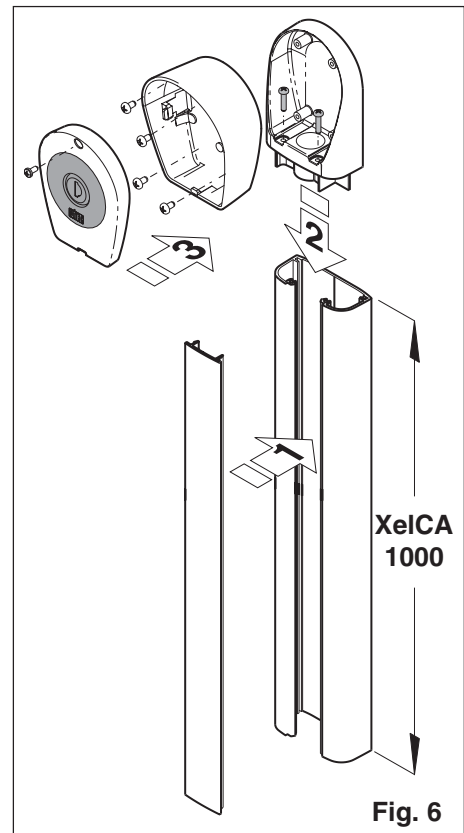

AUTOMATIC ENTRANCE SPECIALISTS

Xel5 - Xel5N

Manuale di istruzioni per selettore a chiave
Key selector installation handbook
Manuel d'installation pour sélecteur a clé
Schlüsselschalter Montage Handbuch
Manual de instalaciòn selector a llave

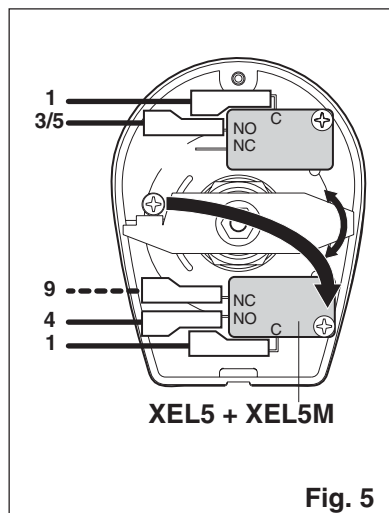
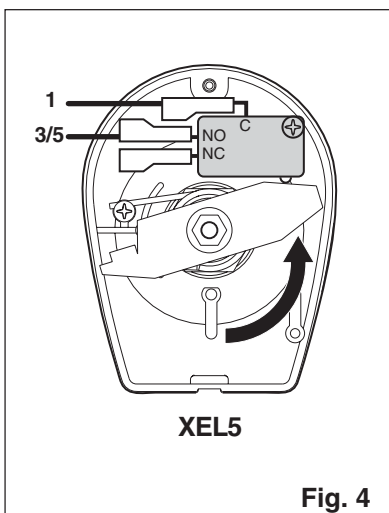
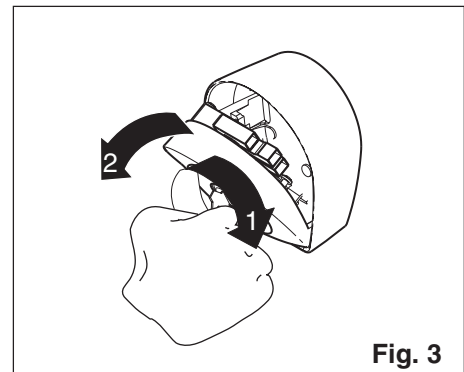
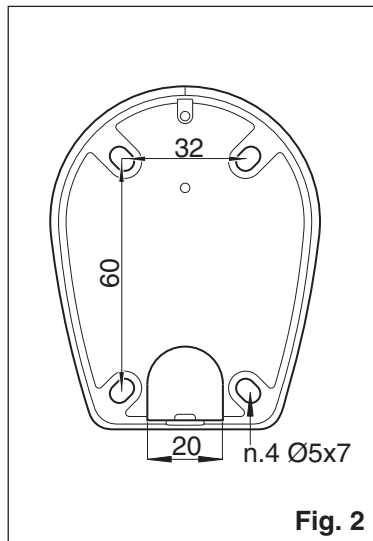
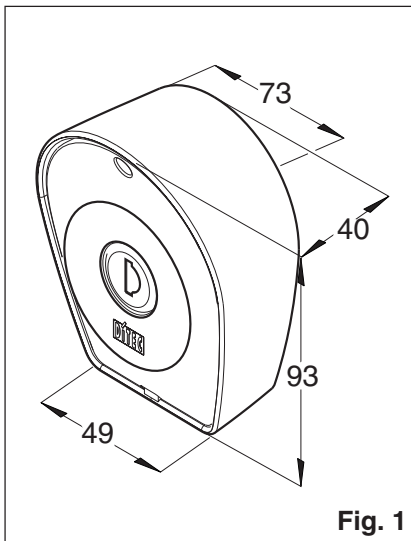

- I XEL5N Selettore a chiave con opzione notturna**
 Con selettore R6/RK6 in posizione notte (Fig. 7-8) oppure con contatto 1-9 aperto (Fig. 9-10), XEL5N consente di aprire e chiudere la porta con funzionamento a uomo presente.
- GB XEL5N Key selector with night-time option**
 With the R6/RK6 selector set to “night” (Fig. 7-8) or contact 1-9 open (Fig. 9-10), consent is given for door opening and closing by XEL5N according to the “person-in-attendance” mode.
- F XEL5N Sélecteur à clé avec option nocturne**
 Avec le sélecteur R6/RK6 en position nocturne (Fig. 7-8) ou avec le contact 1-9 ouvert (Fig. 9-10), XEL5N permet d’ouvrir et de fermer la porte en mode de fonctionnement “homme présent”.
- D XEL5N Schlüsselschalter mit Nachtoption**
 Wenn sich der Wählschalter R6/RK6 in “Nacht”-Position befindet (Abb. 7-8) oder der Kontakt 1-9 geöffnet ist (Abb. 9-10), kann man mit XEL5N die Tür mit Totmannfunktion öffnen und schließen.
- E XEL5N Selector de llave con opción nocturna**
 Con el selector R6/RK6 en posición nocturna (Fig. 7-8) o con el contacto 1-9 abierto (Fig. 9-10), XEL5N permite abrir y cerrar la puerta en modo de funcionamiento “hombre presente”.

